

# ARCHIVED COPY **TORS**

Torsional Orthopaedic Revision System

## DO NOT USE

## User Manual



CONTENTS

CONVENTIONS USED IN THIS DOCUMENT ..... 4

*Warning:*..... 4

*Caution:*..... 4

CONTACT INFORMATION ..... 4

INTENDED USE ..... 5

PLEASE NOTE:..... 5

INDICATIONS..... 5

CONTRAINDICATIONS..... 5

**THE TORS SYSTEM..... 6**

    GENERATOR..... 6

*Front Panel*..... 6

*Rear Panel*..... 6

*TORS Transducers & Cables*..... 7

**SAFETY  ..... 9**

    WARNINGS..... 9

    CAUTIONS ..... 10

**INSTRUCTIONS FOR USE..... 11**

    SETTING UP THE TORS SYSTEM ..... 11

*Power up the Generator*..... 11

*Attach the “Cement” footswitch to the Rear Panel*..... 11

*Optional - Attach the “Soft Tissue” footswitch to the Rear Panel*..... 11

*Assemble the Cement Transducer + Probe*..... 12

*Optional - Attach the Soft Tissue + Single Use Handpiece*..... 12

*Cement Transducer - Connect* ..... 13

*Cement Transducer - Initialise*..... 13

*Cement Transducer - Activate*..... 13

*Cement Removal – Irrigation*..... 14

*Soft Tissue Transducer - Connect* ..... 15

*Soft Tissue Transducer – Initialise*..... 15

ARCHIVED COPY:

DO NOT USE

<i>Soft Tissue Transducer – Change Power Level</i> .....	15
<i>Soft Tissue Transducer – Activate</i> .....	16
<i>Turn Off TORS</i> .....	16
FAULT / WARNING INDICATORS: (SEE ALSO APPENDIX 4: TONES AND BEEPS).....	17
<b>DECONTAMINATION</b> .....	<b>20</b>
REPROCESSING GUIDELINES: IMMEDIATELY AFTER USE.....	21
<i>After Use</i> .....	21
MANUAL CLEANING.....	21
AUTOMATED CLEANING.....	21
CLEANING INSPECTION.....	21
WRAPPING.....	22
STERILIZATION.....	22
<i>Opened in Error</i> .....	22
<i>Cleaning the Generator</i> .....	23
<i>Cleaning the Footswitch</i> .....	23
<b>EQUIPMENT CARE</b> .....	<b>24</b>
<i>Probe Inspection</i> .....	24
<i>Transducer / Probe Usage</i> .....	24
<i>Storage of Equipment between Cases</i> .....	24
<i>Maintenance</i> .....	24
<i>Technical Support</i> .....	24
<b>APPENDICES</b> .....	<b>25</b>
APPENDIX 1: MARKINGS ON THE TORS FRONT AND BACK PANELS.....	25
APPENDIX 2: TORS PARTS LIST.....	27
APPENDIX 3: ELECTROMAGNETIC INTERFERENCE.....	28
APPENDIX 4: TONES AND BEEPS.....	31
APPENDIX 5: REAR PANEL MESSAGES.....	32
APPENDIX 6: TECHNICAL SPECIFICATION.....	33
APPENDIX 7: WARRANTY STATEMENT.....	34

**ARCHIVED COPY:  
DO NOT USE**

## Conventions used in this document

### Warning:



A statement that if not strictly followed could result in injury or loss of life, or a statement that is otherwise required to be a warning.

### Caution:

A statement that if not strictly followed could result in damage to the equipment

## Contact Information

If the unit requires repair please contact us through your local supplier or directly:

RSL Ltd.  
Bremridge House  
Ashburton  
S. Devon  
TQ13 7JX  
UK

Tel: +44 (0) 1364 653899

**ARCHIVED COPY:**  
[www.radleyscientific.co.uk](http://www.radleyscientific.co.uk)

**DO NOT USE**

### Intended use

TORS is an ultrasonic surgical device intended to be used for removal of polymethylmethacrylate (PMMA) bone cement in orthopaedic applications. It is also intended to be used for cutting and cauterising soft tissue during skin and muscle incision to access bone joints in limbs.

### Please note:

- This document does not reference surgical techniques.
- The safety & effectiveness of any ultrasonic surgical equipment is mostly dependent upon the surgeon and nursing staff.

### Indications

TORS is indicated for use in the removal of polymethylmethacrylate (PMMA) bone cement in orthopaedic applications. It is also indicated for soft tissue surgical incisions when bleeding control and minimal thermal injury are important.

**ARCHIVED COPY:**

### Contraindications

- Do not use, if in the judgment of the surgeon, the use of ultrasonic surgical techniques are not in the best interest of the patient.
- Do not use for incising bone.
- The Soft Tissue Transducer is not indicated for the cutting of vessels exceeding 1.5mm in diameter or bone tissue.

**DO NOT USE**

**Please read all Warning & Cautions contained in this document**

# The TORS System

## Generator

### Front Panel

The screen is highly visible, especially in a darkened operating theatre, indicates operating mode selected and gives concise instructions on action required in the event of disruption to normal operation.

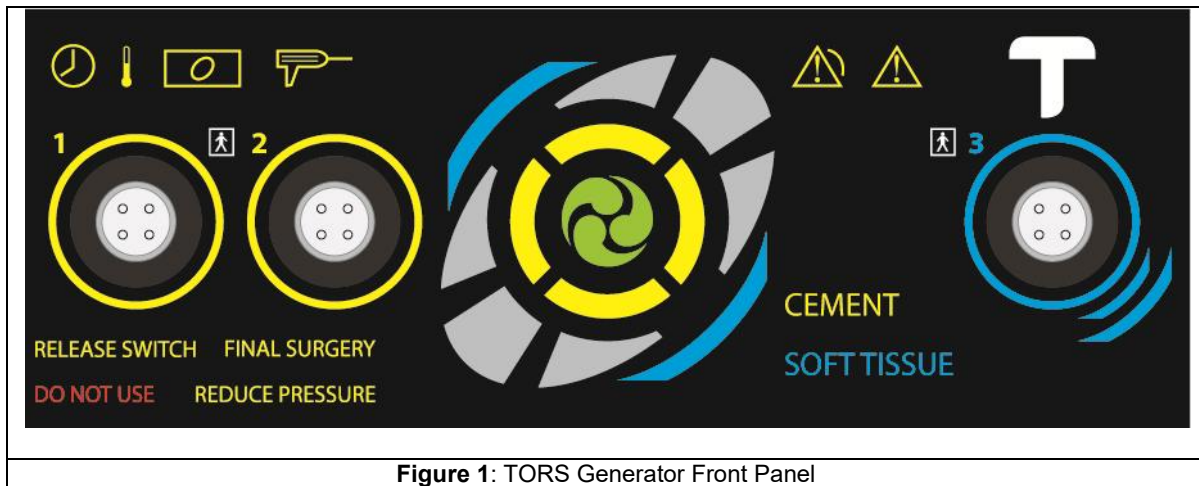

Figure 1: TORS Generator Front Panel

# DO NOT USE

### Rear Panel

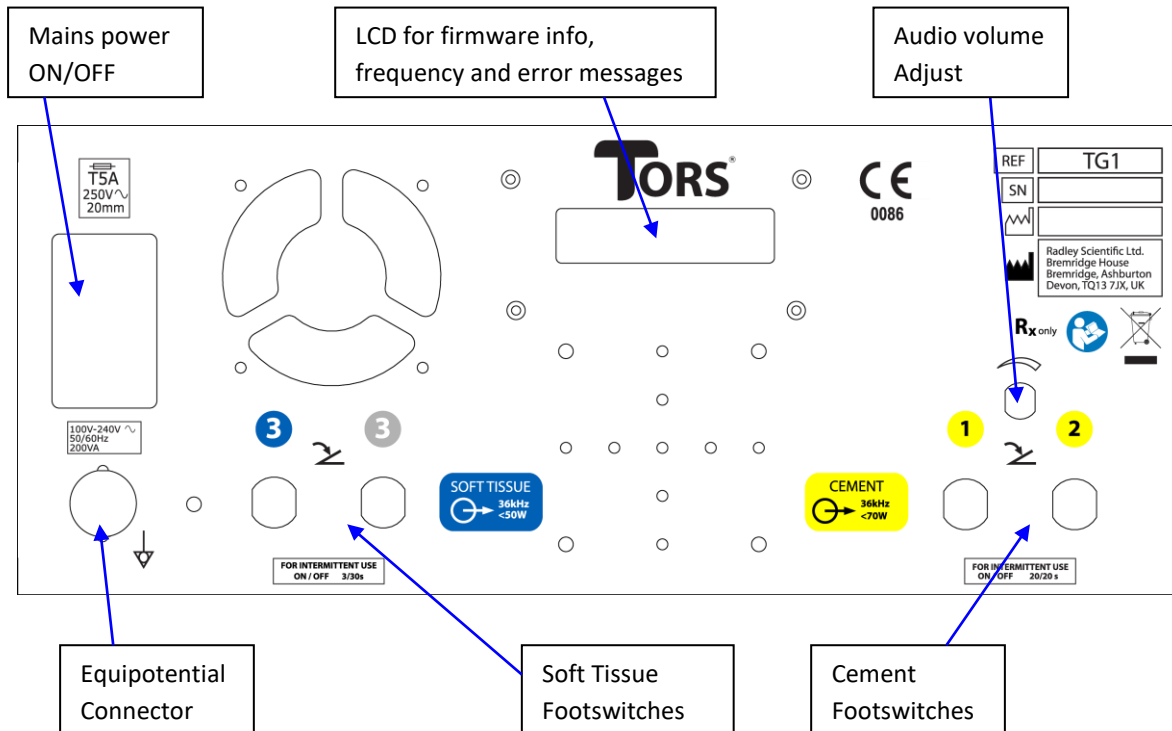

Figure 2: TORS Generator Rear Panel

There is only one user control on the generator itself:

- Volume control (on the rear panel)

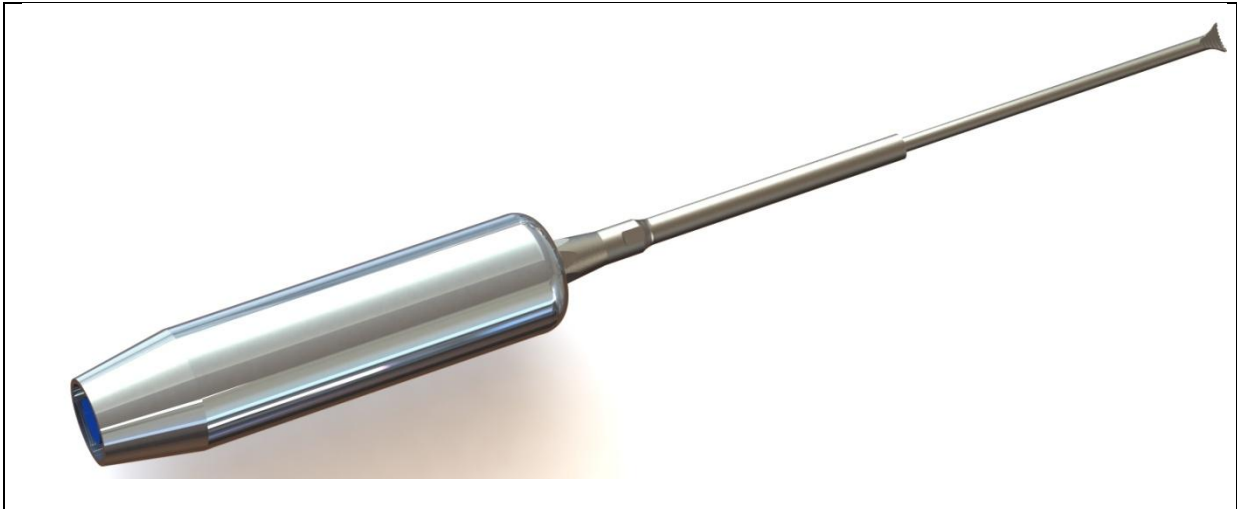

Figure 3: TORS Cement Transducer + Probe

ARCHIVED COPY:



Figure 4: TORS Soft Tissue Transducer + Probe

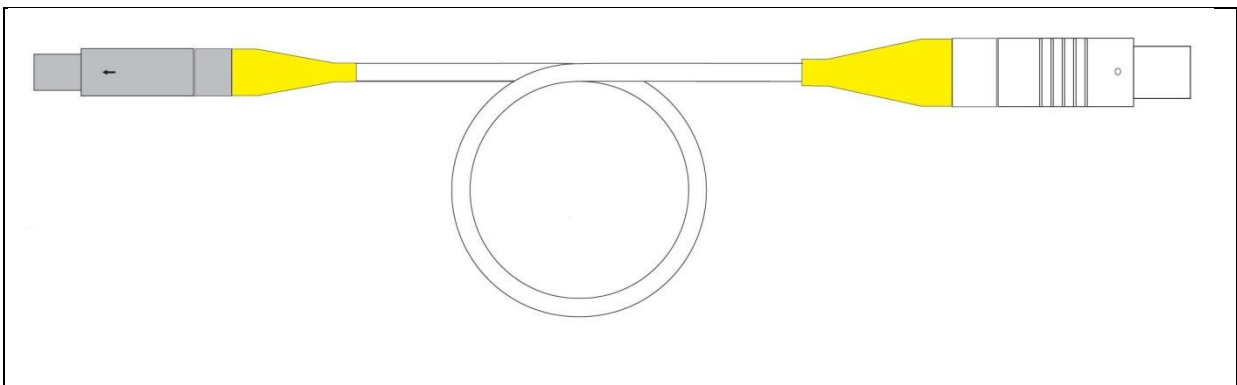

Figure 5: Cement Transducer Cable



## Safety

### Warnings

- This device should only be used by surgeons who are (1) trained in the types of surgical procedures that are to be carried out and (2) trained in the specific use of ultrasonic surgical instruments.
- Do not operate TORS in a potentially explosive or flammable area, or in oxygen rich environments. Note that if the Probe touches anything metal while activated, sparks may be produced.
- The use of TORS in cases where a patient or an operator of the unit has been fitted with a cardiac pacemaker is left to the discretion of the consultant in charge of the procedure although no electrical flow is made through or into the patient and many clinical papers on the use of ultrasound in the proximity of cardiac pacemakers have been published.
- Appropriate protective measures, including smoke evacuation, should be taken to protect users from any smoke, or other aerosols, produced by the use of surgical ultrasound.
- Use extreme caution when using in the vicinity of nerves.
- Handle the acoustics (Transducers and Probes) with care.
- Do not attempt to modify the acoustics. No modification of this equipment is allowed.
- The use of transducers or handpieces not supplied as part of the TORS system may damage the generator and create a safety hazard for the operator and patient.
- Avoid touching or holding the blade at the end of the energized Probe. It is designed to produce heat!
- Other than the activated tip, do not allow probe to be in contact with tissue.
- Irrigate the femoral canal after each activation.
- When guiding the TORS Cement Probe through PMMA, care must be taken not to exert excessive force in order to maintain control of the direction of travel of the Probe.
- Use of excessive force in vicinity of thin bone may cause perforation.
- Avoid resting the blade on skin or other tissue for at least 10s after cessation of energizing as it will have become hot while cutting. Ultrasonic systems dissipate heat quickly. (User may quench hot Probe tip / blade in saline)
- Care should be taken when in contact with tissue between activations, in case accidental activation should occur.
- If the Probe comes into contact with bone, a temperature rise of up to 5°C may be seen.
- Allowing active tip to contact bone may cause damage to the bone.
- Wherever possible avoid contact between the side of active Probe and patient tissue.
- Mains Isolation is achieved by use of the double pole switch located on the rear panel.
- To avoid the risk of electric shock, this equipment must only be connected to a mains supply with protective earth.
- TORS is not MR safe or MR compatible.
- Do not re-sterilize or reuse any Single Use parts.
- Portable RF communications equipment (including peripherals such as antenna cables and external antennas) should be used no closer than 30 cm (12 inches) to any part of TORS, including cables specified by RSL. Otherwise, degradation of the performance of this equipment could result.
- TORS should not be used adjacent to or stacked with other equipment. If adjacent or stacked use is necessary TORS should be observed to verify normal operation in the configuration in which it will be used
- The use of accessories, transducers and cables other than those specified may result in increased emissions, decreased immunity or improper operation.
- There are no user serviceable parts.

## Cautions

- U.S. law restricts this device to sale by or on the order of a licensed physician.
- The nursing staff must be trained so that they are familiar with the equipment to be used.
- Avoid allowing an energized Probe to come into contact with any metal surface.
- Do not sterilize the TORS generator or footswitch
- Do not block or otherwise restrict the vents on the rear and bottom panels.
- Never allow electrosurgical equipment to contact the Probe.
- Always transport TORS using the supplied transport cases.
- TORS has an Equipotential Terminal on the back panel. This is provided for compatibility with other medical systems requiring such connections. This conductor is not intended for protective earthing. Refer to EN 60601-1 for details of use with ME Systems.

- TORS:

**ARCHIVED COPY:**

- i. should be used only for those procedures for which it is indicated.
- ii. should be used with an appropriate power level commensurate with the required task.
- iii. should be used with correct surgical technique.

If used correctly the TORS should cut and coagulate tissue and remove PMMA cement to the satisfaction of the user.

The equipment should inform the user of its status either by audio or visual means, unless ultrasound output is not possible. However, if a fault with the audio or visual indicators occurs whilst a cut is in progress, it may allow that cut to be completed without indication.

- **Electromagnetic Interference**
- This equipment is only suitable for use in hospital operating theatre / operating room.
- The performance of TORS may be degraded if it is subjected to electromagnetic disturbances e.g. an incorrect display that clears automatically once activate switch is pressed/depressed.
- Do not use TORS simultaneously with laser equipment or high frequency surgical equipment.
- This equipment has been tested and found to comply with the limits for a medical device.

However should interference occur, the user can try the following measures:-

1. Turn equipment off and on to confirm the source of the interference.
  2. Increase separation between this equipment and other devices.
  3. Connect this equipment to a power socket different from that to which the other devices are connected.
  4. Consult medical physics department.
- The EMISSIONS characteristics of this equipment make it suitable for use in industrial areas and hospitals (CISPR 11 class A). If it is used in a residential environment (for which CISPR 11 class B is normally required) this equipment might not offer adequate protection to radio-frequency communication services. The user might need to take mitigation measures, such as relocating or re-orienting the equipment.
  - Where replacement Transducers and Cables are required, these must be manufactured by RSL (see Appendix 2 for full listing),
  - See also Appendix 3: Electromagnetic Interference.

# Instructions for Use

## Setting Up the TORS System

### Power up the Generator

- Connect the mains lead to the rear panel of the generator.
- Press the Mains rocker switch up, "I", to switch on.
- The generator will now power up with an audio indicator flourish of tones, conduct a brief full screen illumination test as shown in Figure 8.

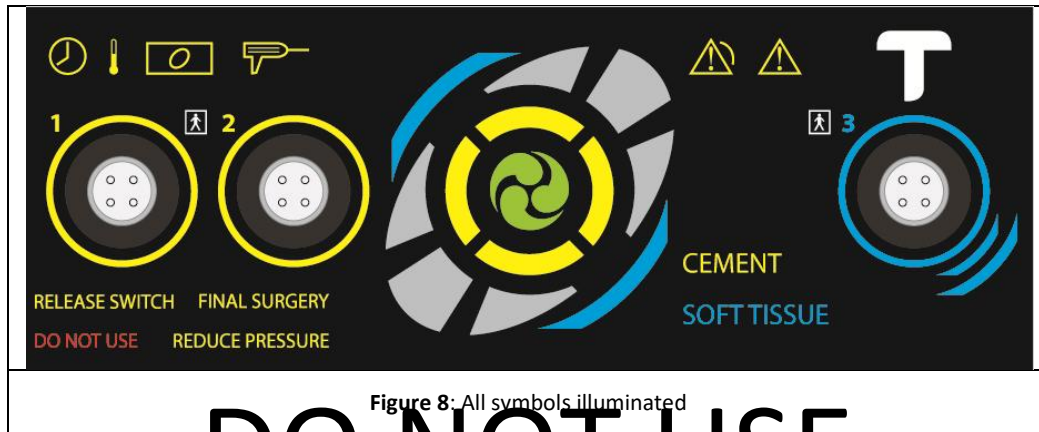

- After approx one second the display will show:

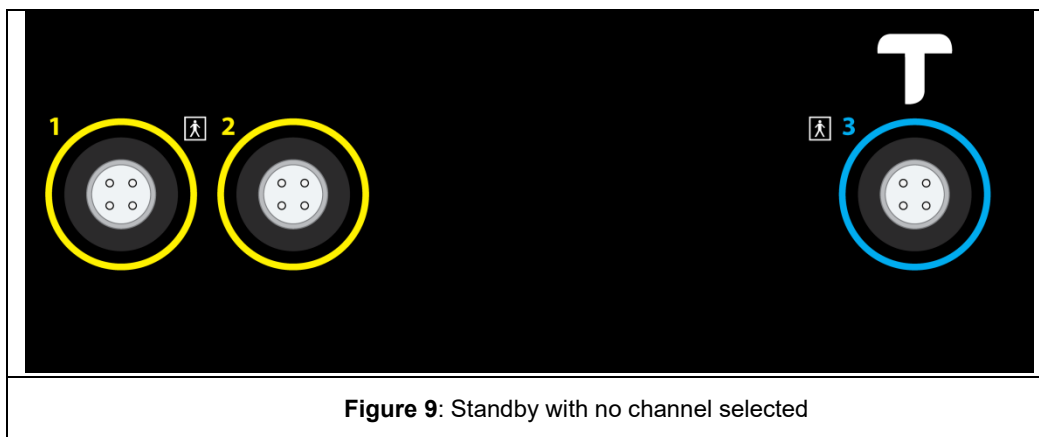

### Attach the "Cement" footswitch to the Rear Panel

- The tube with the **Yellow** + "1" collar attaches to the similarly marked connection.
- The tube with the **Yellow** + "2" collar attaches to the similarly marked connection.

### Optional - Attach the "Soft Tissue" footswitch to the Rear Panel.

- The tube with the **Grey** + "3" collar attaches to the similarly marked connection.
- The tube with the **Blue** + "3" collar attaches to the similarly marked connection.

- Alternatively, the finger switches may be used for the Soft Tissue Transducer.

### Assemble the Cement Transducer + Probe (Applied Part)

- Select the pre-sterilized Cement Transducer.
- Select the appropriate pre-sterilized reusable Probe.
- Select the Single Use Cement Handpiece ( T1AH Axial Grip and Sleeve ).
- Fit the Transducer into the Handpiece. Rotate and click into place – ensure that it is securely connected. See (1) & (2) in Figure 10 below.
- Slide the Handpiece Sleeve over the Transducer horn. Locate the lugs at the base of the sleeve into the grip Handpiece and twist / click into place. See (3) below.
- Using supplied spanners, attach the Probe to the Transducer (4) & (5) below.

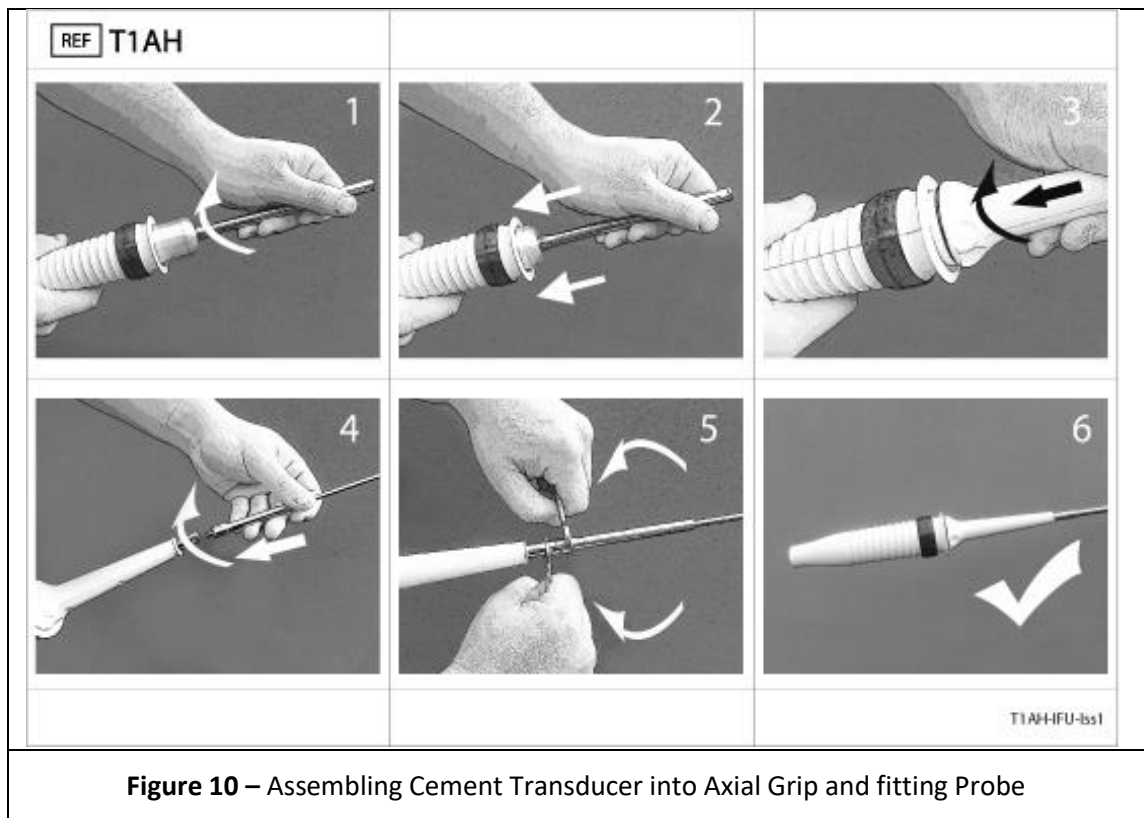

### Optional - Attach the Soft Tissue Transducer (Applied Part)

- Remove the plug cap by pulling the knurled rings on the plug and the autoclave cap.
- Align the red dot on the metal plug with the red dot on the generator socket.
- Connect the Transducer to Generator Channel 3.
- Push the plug into the socket until it clicks.
- To remove, pull back on the knurled part of the plug - **Do not** pull the cable.

## Cement Transducer - Connect

- Connect the Cement Cable ( Yellow coding ) to Generator Channel 1 or 2 ( Yellow rings ) by aligning the red dot on the metal plug with the red dot on the generator socket. Push the plug into the socket until it clicks.
- Connect the other end of the Cement Cable ( Plastic connector ) to the Cement Handpiece. Align the arrow on the plastic connector with the slot in the rear connector on the Axial Grip. Click into place.
- To remove, pull back on the knurled part of the plug - **Do not** pull the cable.

## Cement Transducer - Initialise

- When the surgeon is ready to use the Transducer they must initialize it to enable power. This is done simply by pressing the black activate button or yellow footswitch. The display shows:

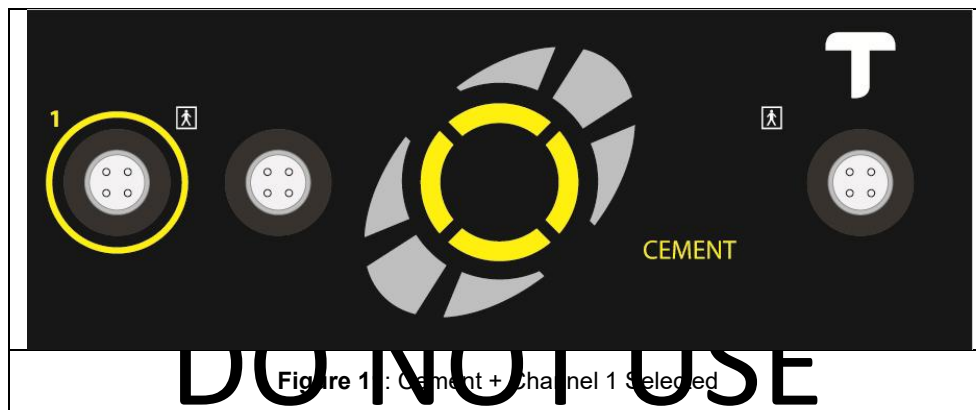

## Cement Transducer - Activate

- Press the black activate button on the handpiece or the yellow footswitch. This will energize the Transducer and Probe for surgery. An audible indicator signifies power delivery with a continuous low pitched tone.

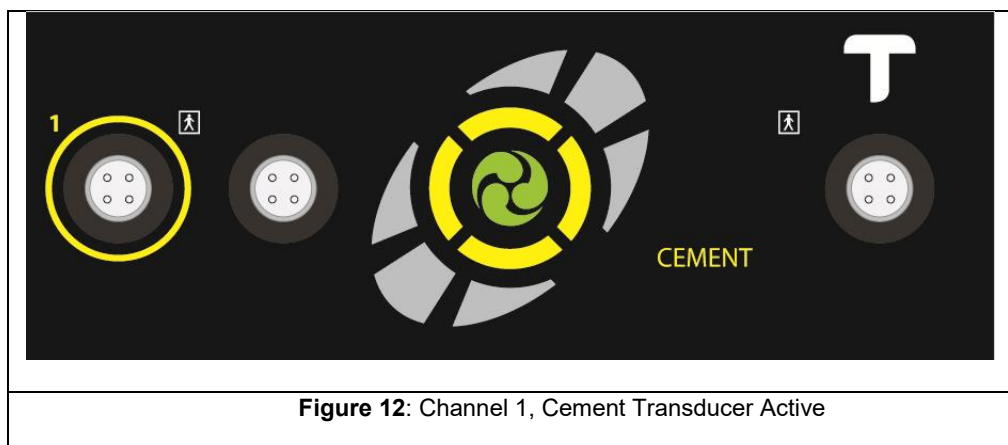

- To stop output release the footswitch or activate button.
- If the footswitch or activate button is held down continuously for 20 seconds the audio indicator sound will change from continuous to pulsed.
- After a further 5 seconds the generator will terminate power.
  - Output power is cut
  - Audible indicator stops

- Displays Warning symbol + Transducer Symbol + Clock symbol.
- These will remain illuminated as long as the footswitch or activate button pressed.
- When it is released, normal operation resumes

### **Cement Removal - Irrigation**

It is important to irrigate the bone canal during the cement removal process for two reasons:- It clears the canal of cement debris, including dust, and it also helps maintain safe operating temperatures within the canal. Such Irrigation systems are standard provision in orthopaedic cases.

It is recommended that irrigation in the form of pulsed lavage or manual irrigation is used after each activation of any Probe.

Do not irrigate *during* an activation as this may compromise the efficacy of the ultrasound transmission, translating to a slower cement removal process. The TORS probes are designed to produce rapid heating at the Probe / PMMA interface, thus softening the cement. Any cooling during this process will impede the desired effect.

Any waste products should be disposed of as per normal hospital procedures.

### **Fume Extraction**

It is recommended that a suitable extraction system is used to remove smoke, aerosols and any associated odors.

Any waste products should be disposed of as per normal hospital procedures.

**ARCHIVED COPY:**

**DO NOT USE**

### Soft Tissue Transducer - Connect

Plug a Soft Tissue Transducer into front Channel 3 ( Blue ring ) by aligning the red dots on the plug and connector receptacle. Push connector and click into place.

### Soft Tissue Transducer - Initialize

- Press the Ch3 grey footswitch to select the channel.
- Audio triple downwards tone.
- Note that it will default to Low Power (single bar). The display shows:



### Soft Tissue Transducer - Change Power Level

- If High Power is required press the grey footswitch again.
- Audio triple upwards tone. The display shows:

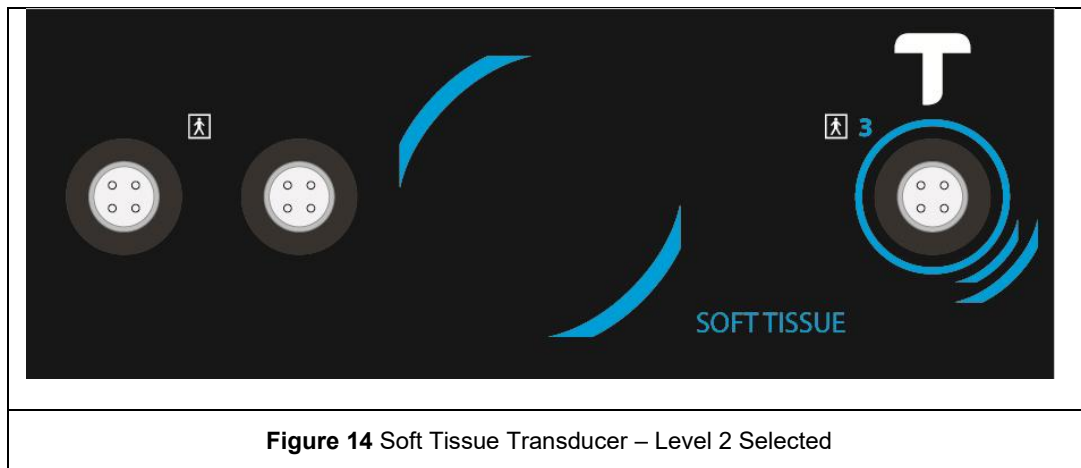

- Further presses will toggle between Low & High Power.

### Soft Tissue Transducer – Activate

- Press the Ch3 blue footswitch. This will energize the Soft Tissue Transducer.
- Audio continuous tone signifies power delivery. Display shows:

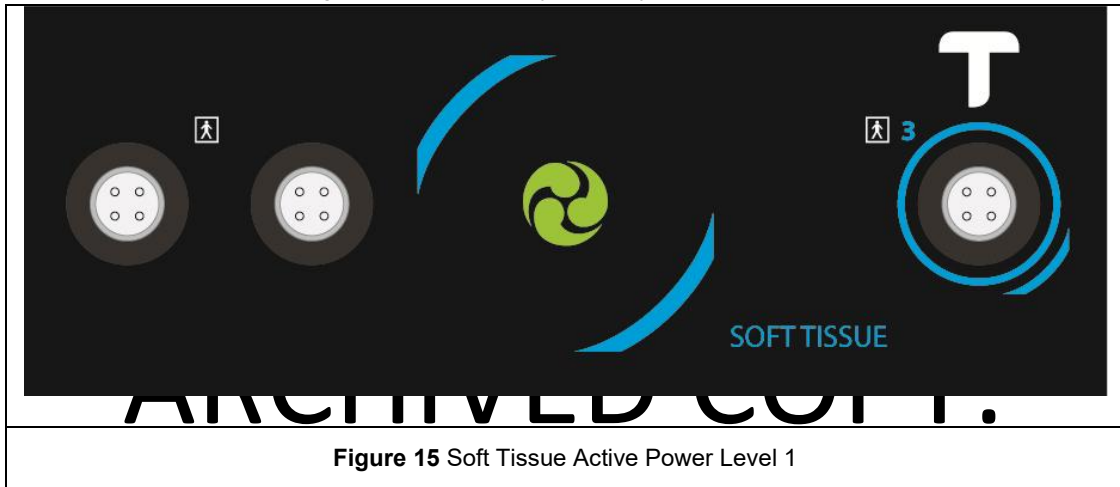

or

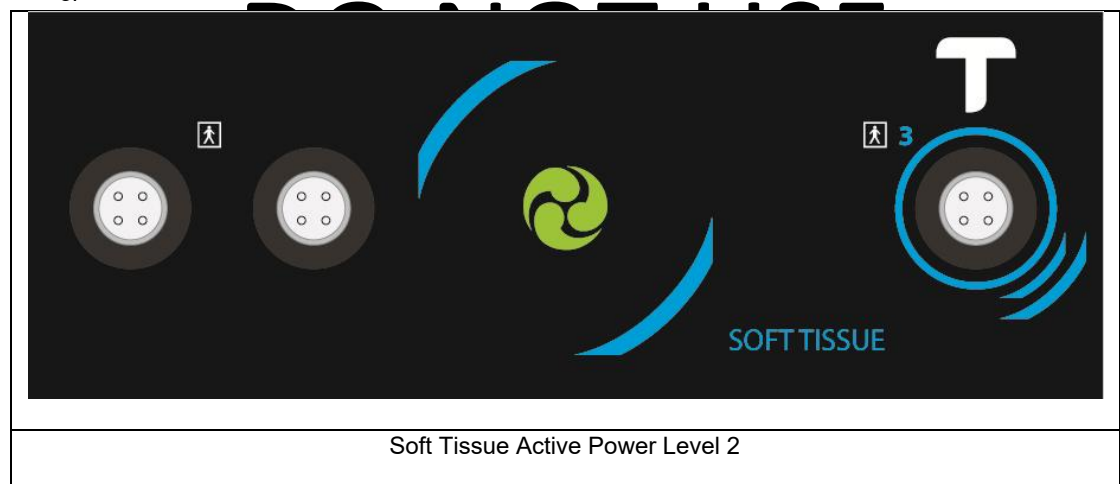

Depending upon power level selected



- To stop output release the footswitch or activate button.
- If the footswitch or activate button is held down continuously for 20 seconds the audio indicator sound will change from continuous to pulsed.
- After a further 5 seconds the generator will terminate power.
  - Output power is cut
  - Audible indicator stops
  - Displays Warning symbol + Transducer Symbol + Clock symbol.
- These will remain illuminated as long as the footswitch or activate button pressed.
- When it is released, normal operation resumes

### Turn Off TORS

- Press the black ON/OFF power switch at the rear of the unit. The screen will become entirely black.

**Fault / Warning Indicators: (see also Appendix 4: Tones and Beeps)**

 <p>The Illuminated yellow triangle indicates that a fault has occurred.</p>	<b>It will always be accompanied by:</b>	
	i. An illuminated symbol indicating the part of the equipment where the fault has occurred	
		
	ii. An illuminated text instructing the user e.g. Reduce Pressure	<p>Or</p>  <p>Or</p>  <p>Or</p>  <p>Or</p> 
	If warning relates to time, the clock symbol also illuminates	
If warning is temperature related the temp symbol also illuminates		

 <p>+</p> 	<p>Cement Transducer has been used 50 times. A high-low tone will sound. Prevents use of the Transducer.</p>
	<p>Or.....</p> <p>Soft Tissue Transducer lifetime is nearly or over 100%. A high-low tone will sound. Prevents use of the Transducer.</p>

<p><b>FINAL SURGERY</b></p> <p>This will only occur during use</p>	<p>Cement Transducer has been used 49 times. A high-low tone will sound. Allows use of Transducer for the duration of the current procedure.</p>
	<p><b>Or.....</b></p> <p>Soft Tissue Transducer lifetime is nearly or over 100%. A high-low tone will sound. Allows use of Transducer for the duration of the current procedure.</p>

	<p><b>INCORRECT TRANSDUCER</b></p> <p>Transducer has been inserted in wrong socket. A high-low tone will sound. Prevents use of the Transducer.</p> <p><b>ARCHIVED COPY:</b></p>
---	--

<p><b>REDUCE PRESSURE</b></p>	<p><b>DO NOT USE</b></p> <p>Too much force is being applied to the TDC during activation. Reduce applied force to improve performance. Excessive force applied during activation can impede cutting performance.</p>
-------------------------------	--

<p><b>RELEASE SWITCH</b></p>	<p>Handpiece button or footswitch held in. A high-low tone will sound.</p>
------------------------------	--

	<p>Transducer frequency too low. A high-low tone will sound. Try again after 5- 10s.</p>
---	--



The generator has detected a problem with the connections to the Transducer. The warning light will flash, and a triple high-high-high tone will sound and repeat. Switch OFF then ON to clear fault. Reenergise the Transducer away from the patient – if fault recurs then change the Transducer and return for service.



**ARCHIVED COPY:**

The generator has detected a problem. The warning light will flash, and a triple high-high-high tone will sound and repeat. Switch OFF then ON to clear fault. Switch Generator back on – if fault recurs then return the system for service.

**DO NOT USE**









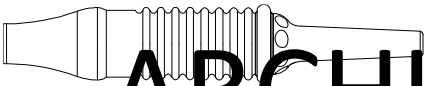

## DECONTAMINATION

The Cement Handpiece is supplied pre-sterilized and is designed for single patient use.

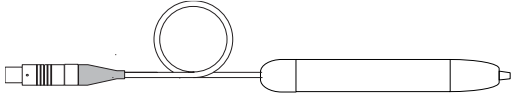
After use the Cement Handpiece should be disposed of as per normal theatre protocol, ideally in a suitably sized biohazard container.

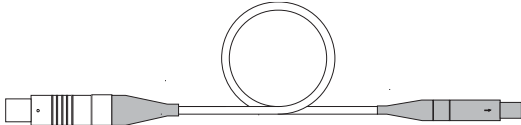
The Cement Handpiece is not designed for cleaning and sterilization after use. Post-operative cleaning and sterilization processes have not been validated by the manufacturer and any attempt at such process could cause the Cement Handpiece to malfunction.

The Transducers and reusable Probes can be reused until their total activation time reaches 50 procedures or 250 minutes. The lifetime is checked at boot time and during use. After the lifetime limit is reached a warning message is displayed upon the generator's screen.

	<p>T1SH - Cement Axial Grip Handpiece (Single Use)  <b>Supplied Sterile</b>          Do Not Use if packaging has been damaged!</p>	
	<p>T1CT - Cement Transducer (Reusable Applied Part)</p>	
	<p>T1TT - Soft Tissue Transducer (Reusable Applied Part)</p>	
	<p>T1CC Cement Transducer Cable (Reusable)</p>	
	<p>T1FMU, T1SMU, T1PMU - Cement Probes (Reusable Applied Part)</p>	

**ARCHIVED COPY:**  
**DO NOT USE**

## Reprocessing Guidelines: Immediately After Use

- Immediately after use wipe down all components and remove any surplus body fluids and debris.

### After Use

Detach the Handpiece from the Cement Transducer by first removing the disposable sleeve. Then pull the Transducer and the handpiece apart.

Detach the Probe from the Cement Transducer using supplied spanners.

Replace the transducers, handpiece cables, reusable probes and spanners back into their original wraps to reduce drying of soil while it is returned to the cleaning facility.

### Single Use Items

Dispose of the Cement handpiece and sleeve as per hospital protocols.

### Manual Cleaning

- Prepare enzymatic cleaning solution (e.g. Gigazyme Plus) to manufacturers instructions.
- Soak soiled instruments in enzymatic solution for 5 minutes.
- When cleaning, fully submerge the instruments in the cleaning solution. Brush with soft non-metallic bristle brush or cloth to remove all traces of blood and debris, concentrating on any crevices, seams, or other surface discontinuities. Clean holes and recesses using an appropriate brush ensuring that the full depth of the feature is reached. Ensure instruments are visibly clean before progressing to the next step.
- Rinse instruments thoroughly with clean running water for 2 minutes. Ensure that blind holes and recesses are repeatedly filled and emptied with running water.
- Dry instruments immediately after final rinse. Do not exceed 140 °C (285°F)

### Automated Cleaning

- Instruments may require manual cleaning prior to automated cleaning to improve the removal of adherent soil. Brush with a non-metallic bristle brush in enzymatic cleaning solution.
- Load instruments such that crevices, seams, surface discontinuities, holes and recesses can drain.
- Clean using the "Instruments" cycle in a validated washer disinfectant and a pH neutral cleaning agent intended for use in automatic cleaning (e.g. Getinge Enzymatic Detergent). The cleaning cycle should incorporate pre-rinse (minimum 3 minutes), wash (minimum 14 minutes), rinse (minimum 7 minutes), thermal rinse (minimum 4 minutes at 93°C / 200°F, and drying steps - Do not exceed 140 °C (285°F).
- An alkaline cleaning solution such as, for example, Serchem pH Plus Detergent, with a pH up to 13.2 may be used instead of, or in addition to, an enzymatic solution.

### Cleaning Inspection

- Inspect all instruments prior to sterilization or storage to ensure the complete removal of soiled surfaces.
- Visually inspect instruments, if soil is still present clean instruments again.
- Inspect cables for wear and damage, ensuring that no cracks, tears, or other damage is found.

- Check to see that Probes are free of scratches.
- Report any damage found to the Radley Scientific representative.

### Wrapping

- Double wrap in accordance with local procedures, using standard procedures wrapping techniques such as those described in HTM 01-01 or ANSI/AAMI ST46-1993
- Label contents of wrapped tray using indelible marker or other sterilization compatible label system.

### Sterilization

- Sterilization is best achieved on the day preceding the surgery, but must be at least one hour prior to use to allow the equipment to cool and stabilize.
- ⚠ Transducers are NOT to be submerged in water to expedite cooling.
- ⚠ Do NOT sterilize the generator or foot switches
- These components have been validated for sterilization by the following method in a vacuum autoclave. The parameters for this being 134-137°C (270°- 277°F) for a minimum of 3 and a maximum of 4 minutes. (If national standards dictate autoclaving up to 18 minutes, this is possible but not preferable.)
  - Next Use - After decontamination, the Transducer can be re-sterilized as above.

**ARCHIVED COPY:  
DO NOT USE**

### End of Life Management

When a Transducer has reached the end of its lifetime please contact your local TORS supplier.

TORS generator and all reusable accessories (including transducers) should be recycled. Contact RSL for return instructions - see end page of this IFU.

**A valid decontamination certificate must accompany each returned Transducer, probe or transducer cable.**

### Opened in Error

In the event of a disposable handpiece being unwrapped in error, it may not be re-sterilized.

Care should be taken to ensure that the cables are not kinked during sterilization as this can produce cracks in the cable and reduce cable life.

## Cleaning the Generator

The TORS Generator may be cleaned as follows:

- i. Dilute a neutral pH detergent according to the manufacturer's directions.
- ii. Using above solution, lightly moisten a soft, clean cloth. Wipe surfaces of the generator.
- iii. Using tap water, lightly moisten a soft, clean cloth. Wipe surfaces of the generator.
- iv. Dry generator surfaces with a soft clean cloth.

## Cleaning the Footswitch

The TORS Footswitches may be cleaned as follows:

- i. Dilute a neutral pH detergent according to the manufacturer's directions.
- ii. Using above solution, lightly moisten a soft, clean cloth. Wipe surfaces of the footswitch.
- iii. Using tap water, lightly moisten a soft, clean cloth. Wipe surfaces of the footswitch.
- iv. Dry footswitch surfaces with a soft clean cloth.
- v. Do not allow any water to enter into the air-hoses.
- vi. Do not detach the air hoses from the footswitch.

**ARCHIVED COPY:**

**DO NOT USE**

# Equipment Care

## Probe Inspection

Before use it is recommended that the Probe be inspected for damage.

TORS Probes are susceptible to damage if forced into contact with metal (e.g. hand instruments and clamps, etc.) when active. The consequence of scratching a Probe is to raise the mechanical stress in the region of the scratch (creating a "stress raiser") when the Probe is vibrating. If the stress is raised sufficiently there is a risk of the Probe suffering metal fatigue and cracking. Fatigue failure is more likely if the stress raiser is close to one of the fixed points of maximum mechanical stress in the vibrating Probe. If a Probe does suffer metal fatigue as a result of a stress raiser causing a crack, the Probe will no longer possess a resonant frequency "recognizable" by the generator. Report to the supplier any Transducer with a Probe that has a scratch, if the scratch is deep enough to be detected by sliding a fingernail over it.

## Transducer / Probe Usage

The Transducer and the titanium Probe of TORS can be decontaminated and reused. This is an important factor in reducing the cost per case. However, they cannot be reused indefinitely and a lifetime is set within which optimum performance can be expected. In order to monitor the so-called "lifetime" of the Transducer and Probe a memory chip is housed inside the cable plug of every Transducer.

For the Soft tissue transducer, every time the generator energizes the Transducer, the duration of the operation is monitored by the TORS then written to the memory chip, overwriting the previous total. When the total run time reaches pre-set markers for warning or termination, the TORS will alert the user.

For the Cement transducer, each time the Transducer is used for a procedure, the remaining number of allowed uses is monitored by the TORS then written to the memory chip, overwriting the previous total. When the total run reaches zero TORS will alert the user and further use will be prevented.

## Storage of Equipment between Cases

It is recommended that the Transducers (with cables) are stored, between cases, in a large autoclave tray and again, care should be taken to ensure that the cables are not kinked close to the connector.

## Maintenance

The hospital is responsible for ensuring that the unit has an electrical safety check performed by qualified service personnel at least once a year.

Do not remove the covers from TORS.

TORS generator does not require periodic calibration. If the generator detects an internal problem it will display a "Service Due" on the rear LCD. If this is seen, contact RSL to arrange repair.

There are no user-serviceable parts in TORS.

Any damage to the Transducers or cables should be reported and the components returned to the supplier at the earliest opportunity.





## Technical Support

In line with the Company's policy of quality assurance and customer care, RSL Ltd. offers a telephone helpline service for users of TORS. This is provided by the TORS manufacturer, RSL Ltd at its facility in Devon, England.

HELPLINE Telephone No. as displayed on the unit is: +44 (0) 1364 653899



APPENDICES

Appendix 1: Markings on the TORS front and back panels

	Model Number
	Serial Number
	Manufacturer
	Date of Manufacture
100-240V	Mains AC Voltage
	Alternating Current
50/60Hz	Mains AC Frequency
200VA	Input Power
	Warning sign
	Type BF Equipment
36kHz	Cement Frequency of Output
<70W	Cement Output Power
For Intermittent Use OFF/ON 20/20s	Cement Duty Cycle
36kHz	Soft Tissue Frequency of Output
<50W	Soft Tissue Output Power
For Intermittent Use OFF/ON 3/30s	Soft Tissue Duty Cycle
	Volume
	Footswitch connection
	Equipotential Connection
	Output channel

ARCHIVED COPY:

DO NOT USE

	Follow instructions for use
	Electrical and Electronic equipment. Return waste to a collection system or treatment and recycling facilities. Follow decontamination instructions before returning waste.
	General Caution Sign

**ARCHIVED COPY:  
DO NOT USE**

## Appendix 2: TORS Parts List

ITEM	Product Code
Cement Axial Grip Handpiece ( Single Use )	T1AH
Cement 200 Ø9 Fan Probe ( Reusable )	T1FM-9-200
Cement 300 Ø9 Fan Probe ( Reusable )	T1FM-9-300
Cement 200 Ø15 Fan Probe ( Reusable )	T1FM-15-200
Cement 300 Ø15 Fan Probe ( Reusable )	T1FM-15-300
Cement 200 Ø20 Fan Probe ( Reusable )	T1FM-20-200
Cement 300 Ø20 Fan Probe ( Reusable )	T1FM-20-300
Cement 200 Ø8 Scraper Probe ( Reusable )	T1SM-8.5-200
Cement 300 Ø8 Scraper Probe ( Reusable )	T1SM-8.5-300
Cement 200 Ø6 Piercer Probe ( Reusable )	T1PM-6.5-200
Cement 300 Ø6 Piercer Probe ( Reusable )	T1PM-6.5-300
Cement 200 Ø8 Piercer Probe ( Reusable )	T1PM-8.5-200
Cement 300 Ø8 Piercer Probe ( Reusable )	T1PM-8.5-300
Cement 200 Ø8 Piercer/Scraper Probe ( Reusable )	T1P/SM-8.5-200
Cement 300 Ø8 Piercer/Scraper Probe ( Reusable )	T1P/SM-8.5-300
Cement 200 Ø8 Two-Lobe Groover Probe ( Reusable )	T1GM-8.5-200
Cement 300 Ø8 Two-Lobe Groover Probe ( Reusable )	T1GM-8.5-300
Cement 200 Ø9 Extractor Probe ( Reusable )	T1EM-9.5-200
Cement 300 Ø9 Extractor Probe ( Reusable )	T1EM-9.5-300
Soft Tissue Transducer + Probe ( Reusable )	T1TT
Cement Transducer ( Reusable )	T1CT
Cement Cable ( Reusable )	T1CC
Generator	T1G
Generator Cart	T1C
Generator Carry Case	T1GC
Cement Footswitch	T1FC
Soft Tissue Footswitch	T1FT
Mains Cable	934
Autoclave Tray	T1AT
Autoclave Tray Mat	T1SM
Instrument Carry Case	T1IC

**Appendix 3: Electromagnetic Interference**

**Table 1**

<b>Guidance and manufacturer's declaration – electromagnetic emissions</b>		
TORS LG4 is intended for use in the electromagnetic environment specified below. The customer or the user of TORS should assure that it is used in such an environment.		
Emissions Test	Compliance	Electromagnetic environment - guidance
RF emissions CISPR 11	Group 1	TORS uses RF energy only for its internal function. Therefore its RF emissions are very low and are not likely to cause any interference in nearby electronic equipment.  TORS is suitable for use in all establishments other than domestic and those directly connected to the public low-voltage power supply network that supplies buildings used for domestic purposes.
RF emissions CISPR 11	Class A	
Harmonic emissions IEC 61000-3-2	No testing – not connection to public mains network	
Voltage fluctuations /flicker emissions IEC 61000-3-3	No testing – not connection to public mains network	

**Table 2**

<b>Guidance and manufacturer's declaration – electromagnetic immunity</b>			
TORS is intended for use in the electromagnetic environment specified below. The customer or the user of TORS should assure that it is used in such an environment.			
IMMUNITY test	IEC 60601 test level	Compliance level	Electromagnetic environment - guidance
Electrostatic discharge (ESD) IEC 61000-4-2	±8 kV contact ±15 kV air	±6 kV contact ±8 kV air	Floors should be conductive. No synthetic material should be used in the environment. The relative humidity should be in the range 40% - 60%.
Electrical fast transient/burst IEC61000-4-4	±2 kV for power supply lines	±2 kV for power supply lines	Mains power quality should be that of a typical commercial or hospital environment.
Surge IEC 61000-4-5	±1 kV differential mode ± 2 kV common mode	±1 kV differential mode ± 2 kV common mode	Mains power quality should be that of a typical commercial or hospital environment.
Voltage dips, short interruptions and voltage variations on power supply input lines IEC 61000-4-11	0 % $U_T^{(2)}$ (100 % dip in $U_T$ ) for 0.5 cycle at: 0°,45°,90°, 135°,180°,225°, 270°,315°  0 % $U_T$ (100 % dip in $U_T$ ) for 1 cycles  70 % $U_T$ (30 % dip in $U_T$ ) For 25/30 cycles  0 % $U_T$ (100 % interrupt in $U_T$ ) for 250/300 cycles	0 % $U_T$ (100 % dip in $U_T$ ) for 0.5 cycle at: 0°,45°,90°, 135°,180°,225°, 270°,315°  0 % $U_T$ (100 % dip in $U_T$ ) for 1 cycles  70 % $U_T$ (30 % dip in $U_T$ ) For 25/30 cycles  0 % $U_T$ (100 % interrupt in $U_T$ ) for 250/300 cycles	Mains power quality should be that of a typical commercial or hospital environment. If the user of TORS requires continued operation during power mains interruptions, it is recommended that TORS be powered from an uninterruptible power supply.
Power frequency (50/60 Hz) magnetic field IEC61000-4-8	3 A/m	No testing	No magnetically sensitive components.
<b>NOTES:</b> <i>Mitigation applied because of environment.</i> $U_T$ is the a.c. mains voltage prior to application of the test level.			

ARCHIVED COPY:  
DO NOT USE

Table 3

Guidance and manufacturer's declaration – electromagnetic immunity			
TORS is intended for use in the electromagnetic environment specified below. The customer or the user of TORS should assure that it is used in such an environment.			
IMMUNITY test	IEC 60601 test level	Compliance level	Electromagnetic environment - guidance
Conducted RF IEC 61000-4-6	3V rms  150kHz to 80 MHz  Outside ISM bands 6V rms In ISM bands 0.15MHz to 80MHz 80% AM at 1kHz  3 V/m 80MHz to 2.5GHz	3V rms    6V rms    3V/m	Portable and mobile RF communications equipment should be used no closer to any part of TORS, including cables, than the recommended separation distance calculated from the equation applicable to the frequency of the transmitter.  Recommended separation distance  $d = 1.2\sqrt{P}$  $d = 1.2\sqrt{P}$ , 80MHz to 800MHz $d = 2.3\sqrt{P}$ , 800MHz to 3.3GHz  where P is the maximum power output rating of the transmitter in watts (W) according to the transmitter manufacturer and d is the recommended separation distance in metres (m).  Field strengths from fixed RF transmitters, as determined by an electromagnetic site survey, <sup>a</sup> should be less than the compliance level in each frequency range. <sup>b</sup>
Radiated RF IEC 61000-4-3	9 V/m 710MHz, 745MHz, 780MHz, 5240MHz, 5500MHz, 5785MHz	9V/m	Interference may occur in the vicinity of equipment marked with the following symbol.
Immunity to proximity fields from RF wireless communications equipment	27 V/m 385MHz  28 V/m 450MHz, 810MHz, 870MHz, 930MHz, 1720MHz, 1845MHz, 1970MHz, 2450MHz	27V/m   28V/m	
NOTE 1 At 80 MHz and 800 MHz, the higher frequency range applies NOTE 2 These guidelines may not apply in all situations. Electromagnetic propagation is affected by absorption and reflection from structures, objects and people.			
<i>a Field strengths from fixed transmitters , such as base stations for radio (cellular/cordless) telephones and land mobile radios, amateur radio, AM and FM radio broadcast and TV broadcast cannot be predicted theoretically with accuracy. To assess the electromagnetic environment due to fixed RF transmitters, an electromagnetic site survey should be considered. If the measured field strength in the in the location in which TORS is used exceed the applicable RF compliance level above, TORS should be observed to verify normal operation. If abnormal performance is observed, additional measures may be necessary, such as re-orienting or relocating TORS.</i>			
<i>b Over the frequency range 150 kHz to 80 MHz , field strengths should be less than 3 V/m</i>			

ARCHIVED COPY:  
DO NOT USE

**Table 4**

<b>Recommended separation distances between portable and mobile RF communications equipment and TORS</b>			
TORS is intended for use in an electromagnetic environment in which radiated RF disturbances are controlled. The customer or the user of TORS can help prevent electromagnetic interference by maintaining a minimum distance between portable and mobile RF communications equipment and TORS as recommended below, according to the maximum output power of the communications equipment.			
Rated maximum output power of transmitter	Separation distance according to frequency of transmitter		
	m		
	150 kHz to 80 MHz $d = 1.2\sqrt{P}$	80 MHz to 800 MHz $d = 1.2\sqrt{P}$	800MHz to 2.5 GHz $d = 2.3\sqrt{P}$
0.01	0.12	0.12	0.23
0.1	0.38	0.38	0.73
1	1.2	1.2	2.3
10	3.8	3.8	7.3
100	12	12	23
<p>For transmitters rated at a maximum output power not listed above, the recommended separation distance <math>d</math> in metres (<math>m</math>) can be estimated using the equation applicable to the frequency of the transmitter, where <math>P</math> is the maximum output power rating of the transmitter in watts (W) according to the transmitter manufacturer.</p> <p><b>DO NOT USE</b></p> <p><i>NOTE 1 At 80 MHz and 800 MHz, the higher frequency range applies</i></p> <p><i>NOTE 2 These guidelines may not apply in all situations. Electromagnetic propagation is affected by absorption and reflection from structures, objects and people.</i></p>			

#### Appendix 4: Tones and Beeps





Rising flourish	TORS is booting to standby mode
No Tone	TORS is in standby mode
Triple tone – low-medium-low pitch	Handpiece Activate Button has been pressed to initialize handpiece (Cement) Handpiece Toggle Button has been pressed to initialize handpiece (Soft Tissue)
Continuous low pitched tone	Acoustic output at the LOW power level
Continuous high pitched tone	Acoustic output at the HIGH power level
Triple tone – low-medium-high pitch	Soft Tissue Transducer is changing from LOW to HIGH power
Triple tone – high-medium-low pitch	Soft Tissue Transducer is changing from HIGH to LOW power
Double beep –high>low pitch	1. The generator has reset itself after a minor problem such as a mistuning event, time-out or over-temperature warning or 2. The generator has encountered a minor problem that requires power switch to be cycled OFF/ON
Triple beep – high>high>high pitch	A more serious problem has been detected

**ARCHIVED COPY:**

**DO NOT USE**

## Appendix 5: Rear Panel Messages

The LCD on the rear panel will display messages that indicate the status of the equipment. The following table shows the possible displays:

Message	Status	Action required
RSL TORS Issue x	Start up message. Shows the Issue number of the software "X"	Now awaiting Transducer to be plugged in
RSL TDCR= xx% Used	Start up message when a Transducer is connected. Shows the % usage of the Transducer.	Now awaiting toggle switch
RSL LO 	The Toggle switch has been operated and the Transducer is ready to be activated.	Now awaiting use
00000Hz HI 	High power is selected (via footswitch or handpiece)	No action required
36000Hz LO 	While Transducer is active the top line will show the frequency. After releasing the switch it will display the final running frequency.	No action required
Release Switches LO 	The active button has been held on for too long. No output.	Release activate button on handpiece or on footswitch
RSL Release Switches	Either Activate or Toggle button (or footswitch) has been pressed at switch on.	Release Activate or Toggle button when switching on Generator
Check Transducer Ease Grip and Retry	Transducer has been loaded too heavily	Release switch, then reactivate using less pressure on the jaw
Transducer Limit LO 	Transducer is approaching 100% lifetime. Final use.	Allow Transducer to cool. Replace Transducer after use
Change Tdcr Transducer Limit Transducer Limit Ready	Transducer has reached 100% lifetime and must be replaced	Replace Transducer
Change Transducer Restart	Transducer frequency too low and feedback signal is low.	Switch supply off & on. Replace Transducer if seen 3 times
Transducer Leakage Change Tdcr	Generator has detected voltage on the Transducer.	Switch supply off & on. Replace Transducer if seen 3 times
Frequency Error Service due	The generator has detected a serious internal problem.	Switch supply off & on. If message seen again Generator requires service.

ARCHIVED COPY:  
DO NOT USE

## Appendix 6: Technical Specification

Model Nos:	See Appendix 2	
Dimensions:	Generator:	340mm (width) x 95mm (height) x375mm (depth) 13.4" (width) x 3.7" (height) x 13.4" (depth)
Weight:	Generator:	4.3 kg
	Transport case:	10.5 kg (loaded with generator)
	Transducer:	0.37 kg
Fuse Type:	T5A, 250V, 20mm (2 off)	
Cordset	Contact RSL for recommended type	
Power supply input	100V - 240V, 50/60Hz	
Power consumption	200VA	
Cement Output - Frequency of operation	36kHz	
Cement Output – Power	<70W	
Cement Mode of Operation	Intermittent ON/OFF, 20/20s	
Cement Transducer Classification:	Type BF	
Soft Tissue Output - Frequency of operation	36kHz	
Soft Tissue Output – Power	<50W	
Soft Tissue Mode of Operation	Intermittent ON/OFF, 5/50s	
Soft Tissue Transducer Classification:	Type BF	
Accuracy of frequency display	1%	
Insulation Classification	Generator:	Class 1
Transducer	Titanium, Stainless steel, and plastic Autoclavable maximum 50 cycles/	
Environment for Transportation & Storage:	Temperature: -10°C to +50°C Relative humidity: 10% to 90% Atmospheric pressure: 50kPa to 106kPa	
Environment for Use:	Temperature: +10°C to +30°C Relative humidity: 30% to 75% Atmospheric pressure: 81kPa to 106kPa	

RSL Ltd. will make available on request circuit diagrams, component part lists, descriptions, calibration instructions to assist to service personnel in parts repair.

TORS has been designed and built in accordance with ISO 13485: 2016 Quality Assurance standard for medical devices.

CE conformance has been certified and the equipment complies with:

IEC 60601-1:2005 + CORR. 1:2006 + CORR.2:2007 +  
A1:2012  
EN 60601-1:2006 + A11:2011 + A1:2013  
ANSI/AAMI ES60601-1:2005/ (R) 2012

## Appendix 7: Warranty Statement

Subject to the terms and conditions listed below, Radley Scientific Ltd. (hereafter called "the Company") guarantees to replace or repair free of charge any defective parts of TORS notified within the warranty period. This applies to the hardware defined below for the purposes of warranty claims made by any party supplied directly by Company.

### Conditions of Warranty:

1. The Warranty covers the electronic system and ancillary components including the generator and footswitch, and applies to defects or faults that are reported to the Company, or its approved service facility, within ONE YEAR from the date of purchase.
2. Where transducers, cables or reusable probes are purchased separately or as part of the electronic system, the Warranty applies within the criteria of Clauses 5 and 6.
3. Where transducers, cables or reusable probes remain the property of the manufacturer the Warranty does not apply. If the Company loans a handset for use with the rest of the system the Company retains responsibility for performance.
4. The Warranty specifically excludes the disposables (handpieces and single-use probes). The disposables are detachable consumables for use with the transducer. They are for single use and are disposed of thereafter. Its condition and sterility is guaranteed up to the expiry date shown on the packaging label.
5. The Warranty relates to any components in Clauses 1 and 2, which are faulty or below specification as a result of inferior workmanship or materials. At the Company's expense the Company will conduct analysis, repair such faults, update to the relevant specification, re-test, re-calibrate and certify as necessary. For handsets this will take into account the additional criteria of Clause 6.
6. Transducer warranty criteria are defined as follows.
  - Cable, connector, acoustic system within (including waveguide) and transducer case are guaranteed against defective parts, materials or workmanship for 9 months from invoice date whether used or not, or until the transducer reaches end of life ("transducer limit") through use.
7. This Warranty does not cover accidental damage to, or fair wear and tear on, any part of the system.
8. This Warranty is only valid for use in the purchasing hospital and when used by personnel trained by the Company or its authorised distributors.
9. If a repair of a fault is required following expiry of the warranty, the Company will conduct analysis and submit a quotation to the customer stating recommended action and cost to the customer.
10. In the unlikely instance of the equipment requiring recall the Company will contact the purchasing hospital immediately and will, at the Company's expense, collect the relevant components.

ARCHIVED COPY:

DO NOT USE

**ARCHIVED COPY:  
DO NOT USE**



ARCHIVED COPY:

DO NOT USE



Bremridge House  
Ashburton  
S. Devon TQ13 7JX  
UK

Tel: (44) (1364) 653899 – Helpline

[www.radleyscientific.co.uk](http://www.radleyscientific.co.uk)